



JULY 2007

VOLUME 16 • ISSUE 7

# Showfish *coast*

PROVIDING EDUCATION AND CAMERADERIE TO PEOPLE WHO ARE INTERESTED IN KEEPING TROPICAL AND TEMPERATE FISH AND OTHER AQUATIC LIFE

NEXT MONTH'S MTG: AUG 5

## Meeting: Sunday July 1, 1:00 to 5:00 p.m.

*Remember—the coastal cities offer reprieve from the heat of July!*

Come and spend a comfortable afternoon with other fish nuts, maybe apply for a passport at the local library for that long anticipated trip to Central America or Singapore. Spouse gets dreadfully, hostilely bored? Remember the malls that are just across or down the street, complete with movie theatres; you can drop the spouse there while you come listen to fish stories.

There will be our usual meeting, raffle, and auction this month. See you there!

## Excellent News!

According to this month's Practical Fishkeeping enewsletter, four or five satellite populations of the Galaxy Rasbora have been found. Sadly, the local population is still in a position where catching and selling these tiny fish (even if it means selling them unto extinction) means that, some nights, the children don't go to bed hungry.

### Table Of Contents

MEMBERSHIP NEWS .....	2
SUMMARY OF JUNE MEETING .....	2
SPONSORS .....	3
IMPROVED FILTRATION FOR CICHLIDS .....	3

CLUB INFORMATION (WHO, WHEN, WHERE) .....	5
AUCTION BAG LABELS .....	6
AUCTION REGISTRATION FORM .....	7

The Showfish is the newsletter of California's Organization of Aquatic Show Tropicals (COAST), a 501(c)(7) not for-profit association registered in California. It is published six to twelve times a year and is a benefit of membership in COAST. The information and opinions expressed in articles are those of the author and may not reflect those held by COAST or other COAST members.

Showfish is printed and distributed at cost by Mike and Elaine McCabe of McCabe Printing, 11918 E Rosecrans Ave Suite B, Norwalk, CA 90650.

**Reprint Policy:** Articles and graphics which are marked with a © symbol or annotated as Copyrighted or "property of ..." may not be reprinted without the owner's permission. Unmarked articles and graphics may be reprinted by other fish clubs; please send two copies of the newsletter containing the reprint to C. A. Marelius, 16229 Armstead St. Granada Hills, CA 91344 or email a copy to [cmarelius@verizon.net](mailto:cmarelius@verizon.net).

**Exchange Policy:** COAST will exchange newsletters which contain information about fish and the fish hobby with other fish clubs. Please notify the Showfish editor, C.A. Marelius, if your club would like to participate in an exchange program.

## Membership News

### *New Members – Welcome to the club!*

Carlos Barrientos, Downey

### *Past Due – This is your last Showfish*

Rich Beckett

Ryan Scott

Marvin Zabie

### *Memberships that were due in June:*

Steve Ehrlich

Harold Lieberman

Neil Zarske

### *Memberships Due in July:*

Ron Estrada

## Summary of Last Month's Meeting –

Brian Downing gave a presentation of his tour of some of the world's better-known public aquariums—from the back of the displays. The sophistication, scale, and complexity each aquarium's setup varied in direct proportion to its funding, its size, and its age, but time and again the systems used were larger versions of the ones we use in our fish rooms. The older aquariums still used concrete walls as the back and sides of their displays or as behind-the-scenes tanks (sometimes their original tanks, decades old). The newer aquariums used plastic extensively, but still used concrete on their huge tanks.

*Every aquarium offered something beautiful, unique, and informative, whether it portrayed the Victorian-era "display a slice of life" concept of aquarium or the Monterey Bay Aquarium's "learn to preserve life" concept of stewardship.*

Aquariums with little funding relied on volunteers to take care of the filtration and water condition on each individual tank, while aquariums with generous funding had modern, semi-automatic systems that took up entire rooms and were maintained by engineers and biologists.

Vinny Kutty will give his presentation later in the year.

.....

A Lake Victorian male cichlid, once known as *Haplochromis Zebra Obliquidens*—not in his best color (or a very good photo) but obviously a fish worth having. The female lacks the red.



You know you're too slow when – other snails lay their eggs on you.



## Manufacturers and Vendors Supporting our Club

*Please support these companies when shopping for food, products, and equipment.*

- Eugene Danner Manufacturing**, Islandia, NY 11749
- Hikari Sales**, Shawn Bonham, Hayward, CA 94545
- Energy Savers Unlimited, Inc.**, Carson, CA 90746
- Omega Sea, Ltd**, Marty Crews, Perry, OH 44801
- Jungle Laboratories**, Lisa Hendrix, Cibolo, TX 78108
- Hamilton Technology Corp.**, Gardena, CA 90248
- Marine Enterprises Int'l, Inc.**, Baltimore, MD 21221
- PetSolutions** Beavercreek, OH 45434
- Drs Foster and Smith**, Janine Fuchs, Rhinelander, WI
- Perfecto Myg, Inc.**, Susan Rogers, Noblesville, IN
- Aquarium Systems**, 8141 Tyler Blvd., Mentor, OH
- HBH Pet Products**, PO Box 967, Springville, UT
- Aquaria**, 6100 Condor Dr, Moorpark, CA 91302
- CASCO**, 17719 Valley View, Cerritos, CA 90703
- Marc Weiss Companies, Inc.**, 5935 Ravenwood Rd., Fort Lauderdale, FL 33312
- San Francisco Bay Brand, Inc.**, Allen Green, 8239 Enterprise Dr., Newark, CA 94560
- Tetra**, Dick Razzi, 301 Commerce Dr., Blacksburg, VA 24060



**THE ORIGINAL  
CAVES -  
RINO'S**



Phone 951-657-4634  
**Caves For Sale**

### Improved Filtration for Cichlids

*Jim Carmark, 12 Fairmont St., Hull, MA 02045* "Reprinted from *Buntbarsche Bulletin*, official publication of the American Cichlid Association, Inc (ACA)"

Our beloved cichlids cannot be exactly characterized as "clean" fishes. Between their hefty appetites and ability to consume large amounts of foods, fairly large body size, and their digging behaviors, most cichlids can easily turn a tank into a swamp. Many conventional filters, such as undergravel and canister filters, require vigilant maintenance on a frequent basis. There are several techniques that may be easily adapted to enhance your filtration system or extend the maintenance interval.

One easily built addition is a **sludge chamber** pre-filter. The best looking is a custom-built plexiglass chamber with built in drains. The chamber should be as tall as possible, usually the same as the tank height (see the diagram in Figure 1). The output from the chamber can go to either a trickle filter or canister filter. With a little forethought, a suction-intake outside filter (Aquaclear, Whisper, etc.)

can be easily modified also.

A cheaper, less attractive and more bulky system can be constructed from milk crates and a plastic pail. Make sure the pail is at almost exactly the same height as the top of the tank, or at least one inch above the water level of the aquarium (use the crates). Use several large siphons to bring water into the bucket, with the intake to the canister filter located on the opposite side. To help trap the detritus and sludge, use some type of very coarse media, such as plastic gutter screen, plastic scrub pads, monofilament fish line, or one of the bioball-type systems.

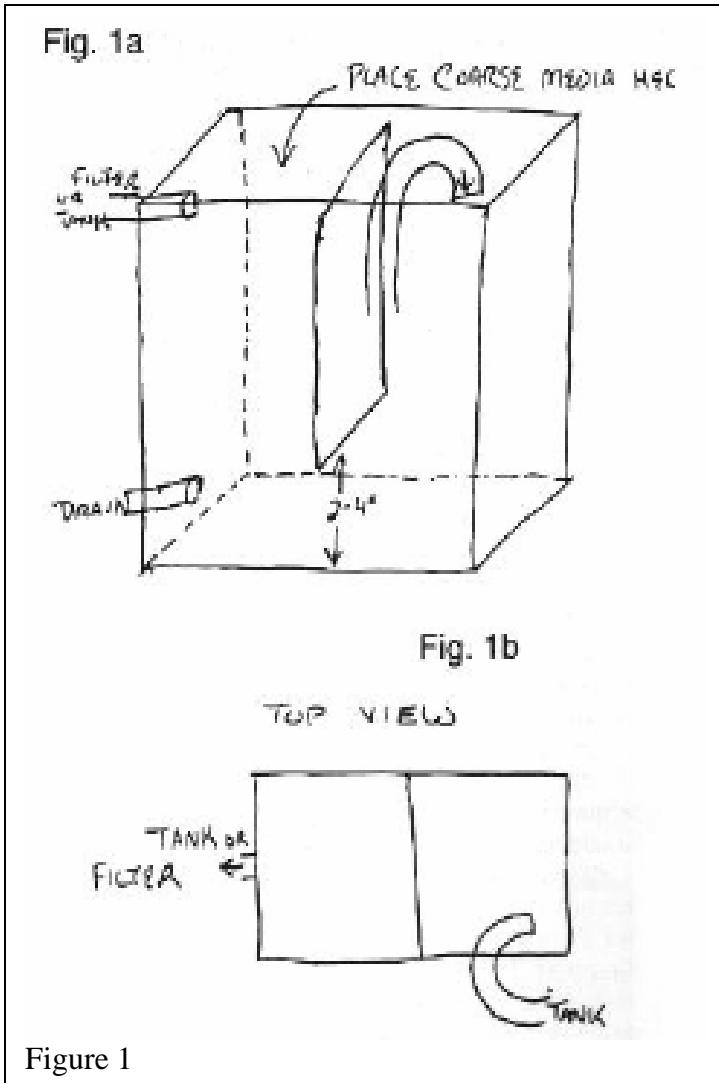

For really large aquaria or multitank systems, an inclined **plate settling** system can effectively remove large volumes of detritus. The basic principal is that because of friction, micro-turbulence and several other factors, suspended solids will tend to accumulate on inclined surfaces. These solids will accumulate in ever-thicker layers until gravity overcomes friction and the sludge 'avalanches' down to the bottom chamber, where it can be easily removed. See the diagrams in Figure 2 for clarification. The inclined plate can be easily constructed from pieces of flat or ripple fiberglass roofing material and threaded stainless steel rod. Use 1/4 inch rod with 1/2 - 3/4 inch long pieces of 1/2 inch PVC pipe as spacers. Regular (cheap) threaded steel rod may be used only if covered with vinyl tubing, with the bolts and ends carefully sealed with silicone.

### Beware Toxicity! - Materials to Avoid in Construction

A note about metals and fish might be appropriate here. Most people are aware that copper, brass, and bronze can leach toxic heavy metal ions into water passing through fittings or tubing made from them and that lead can enter the water from solder joints. However, **most** metals are toxic, with some being more toxic than others. Even stainless steel will leach out measurable amounts of nickel, chromium, vanadium, molybdenum, cobalt and other rarer metals. Silver, selenium and zinc are especially toxic to most invertebrates and many fish. Iron has relatively low toxicity, but **most** 'steel' fasteners, such as rods, bolts, nuts, screws, etc. are really coated with a substantial layer of "protective" plating, usually cadmium, nickel, zinc, or chromium. These

layers are easily dissolved by aquarium waters due to acids and salts in the system. **All** bolts, nuts and screws should be stainless steel wiped with a thin layer of silicone rubber. Even aluminum foil can easily poison a tank when used as a reflector or backpiece around filters. Don't assume that the screws, bolts, or hinges used for a wood canopy can't kill a tank - it often has. A nickel dropped into a 100 gallon tank can dissolve toxic levels into the water in as little as a week. Also, be cautious of using any adhesive except silicone. Superglue is quite toxic under certain conditions, as are many epoxies, hot-melt glues and rubber cements. Plexiglass cement, silicone rubber, and most polyester (fiberglass resin) based coatings are safe for water contact. When constructing filters, lights, etc., remember that the large amounts of water vapor can raise havoc with wood, swell plexiglass (which is why tops curl), corrode almost any metal and leach plasticizer from any plastics (except polyethylene). If in doubt, **don't**.

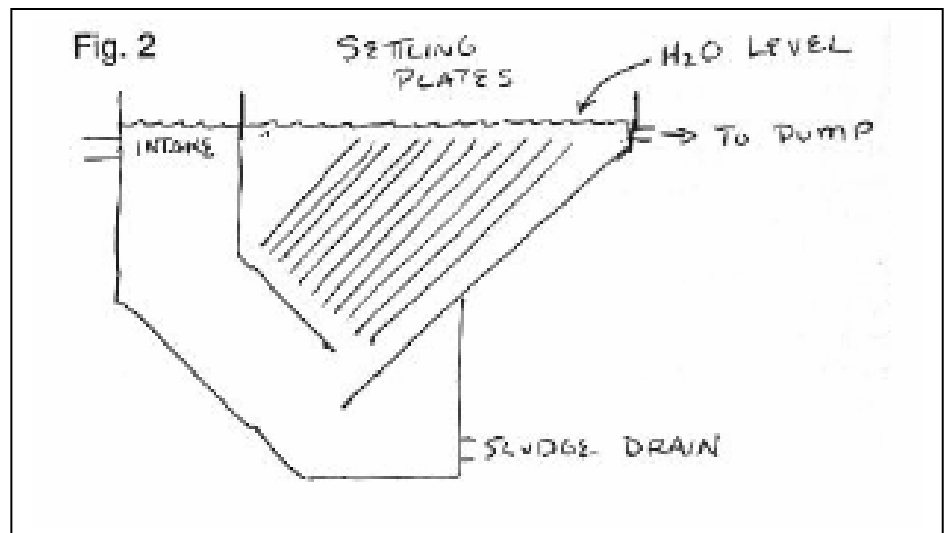

## Meeting and Club Information

### Board of Directors

Brian Downing   Pauline Jackson   Rahul Kumar   (Open)   Ron Jackson   Rick Marelius



Mamie Nash   (Open)   Kirk Bean   Charlotte Marelius   Tom Varin   Ron Nash   Mike McCabe

<b>PRESIDENT</b> Brian Downing <a href="mailto:brianjdowning@msn.com">brianjdowning@msn.com</a> 858-759-4841	<b>EDITOR</b> Charlotte Marelius <a href="mailto:rcmarelius@verizon.net">rcmarelius@verizon.net</a> 818-360-7102	<b>DIRECTOR</b> Rick Marelius <a href="mailto:rcmarelius@verizon.net">rcmarelius@verizon.net</a> 818-360-7102
<b>VICE PRESIDENT</b> Kirk Bean <a href="mailto:kb1752@sbc.com">kb1752@sbc.com</a> 858-361-8745	<b>PROGRAM CHAIR</b> Rahul Kumar <a href="mailto:cichlididiot@gmail.com">cichlididiot@gmail.com</a> 310-824-1787	<b>DIRECTOR</b> Mamie Nash <a href="mailto:coast@ronaldvnash.com">coast@ronaldvnash.com</a> ; 714-226-0045
<b>TREASURER</b> Pauline Jackson <a href="mailto:imbubsie@aol.com">imbubsie@aol.com</a> 714-638-8445	<b>TREASURER APPRENTICE</b> Barry Heller <a href="mailto:deep6ed@aol.com">deep6ed@aol.com</a> 818-848-1069	<b>WEBSITE DEVELOPMENT / ADMIN</b> Tom Varin <a href="mailto:tvarin@usa.net">tvarin@usa.net</a> 714-962-8541
<b>RECORDING SECRETARY</b> (open)	<b>AUCTIONEER</b> Duncan Mahoney <a href="mailto:dmahoney@usc.edu">dmahoney@usc.edu</a> 310-391-3704	<b>PUBLISHER</b> Mike and Elaine McCabe <a href="mailto:mccabeprint@yahoo.com">mccabeprint@yahoo.com</a> 562-868-1992
<b>CORRESPONDING SECRETARY</b> Ron Jackson <a href="mailto:katfishron@aol.com">katfishron@aol.com</a> 714-638-8445	<b>MEMBERSHIP CHAIR</b> (open)	<b>AUCTION CHAIR</b> Ron Nash <a href="mailto:coast@ronaldvnash.com">coast@ronaldvnash.com</a> ; 714-226-0045

**Discussion Group:** <http://pets.groups.yahoo.com/group/coastfishclub/>

**Website:** <http://www.coastfishclub.com>

**Newsletter:** The club's newsletter, the Showfish, is published at least six times a year (usually 10 to 12) and mailed to arrive a day or two before the meeting. The current issue is published on our discussion group in the Files section around the 25<sup>th</sup> of the month, and previous months' Showfish are published on our website.

(Meeting and Club Information, continued)

**COAST meets the first Sunday of every month from 1:00 to 5:00 p.m. unless otherwise noted.**

Meeting agendum:	12:30	Board Meeting
	1:00	Meeting begins; general announcements
	1:30	Presentation begins
	2:45	Auction begins
	4:15-4:30	Auction usually ends; check-out begins
	5:00-5:30	Vacate the room

**Where do we meet:**

We meet in the Costa Mesa Neighborhood Community Center in the Victoria Room (usually) or the Harper Room. The Center is a brown brick building between a fire station and Lion’s Park. Closest major intersection is 19<sup>th</sup> and Harbor Blvd.

Costa Mesa Neighborhood Community Center  
1845 Park Avenue  
Costa Mesa, CA

**Upcoming meetings for 2007:**

July 1	Speaker and Topic:	October 7	Speaker and Topic:
August 5	Speaker and Topic:	November 4	Speaker and Topic:
September 2	Speaker and Topic:	December 2	Speaker and Topic:

**Auction Bag Labels** (The LOT NO. is made of your member number followed by the bag number. Example: member 97 is selling 5 bags of fish. The lot numbers are 97-1, 97-2, 97-3, 97-4, and 97-5.)

<p><b>LOT NO.</b> _____ <b>Qty</b> _____</p> <p>Genus/Species or common name</p> <p>Phone No. _____</p>	<p><b>LOT NO.</b> _____ <b>Qty</b> _____</p> <p>Genus/Species or common name</p> <p>Phone No. _____</p>
<p><b>LOT NO.</b> _____ <b>Qty</b> _____</p> <p>Genus/Species or common name</p> <p>Phone No. _____</p>	<p><b>LOT NO.</b> _____ <b>Qty</b> _____</p> <p>Genus/Species or common name</p> <p>Phone No. _____</p>
<p><b>LOT NO.</b> _____ <b>Qty</b> _____</p> <p>Genus/Species or common name</p> <p>Phone No. _____</p>	<p><b>LOT NO.</b> _____ <b>Qty</b> _____</p> <p>Genus/Species or common name</p> <p>Phone No. _____</p>

SELLER NAME:		Date	Member No.		<b>Auction Rules</b> You must be a current member of COAST to sell items at the auction.  NOTE WELL: Buyer Beware! Auction items are sold "as is" and COAST does not guarantee items sold at auction as to health, accuracy, working condition, suitability, etc.  BAGGING FISH: Use proper fish bags. Double bag the fish. <b>Bag adult males separately from females and separate territorial or aggressive fish</b> from each other to minimize damage or death. Individual bags can then be taped together to be sold as pairs or groups.  Do not feed fish the night before. Bag fish in clean water, with a ratio of 1/3 water to 2/3 air. Bag fish at home please.  LABELLING: Label bags with member no. and bag no., qty and sex of fish, genus/species, and phone no. Paper labels are preferred. Use Sharpie for marking on bags if reqd.  PLANTS: Plants may be single bagged and do not need to be submersed in water. Label as for fish.
BAG NO.	QTY	NAME OR DESCRIPTION	Sold for Amount	Mark if donating	
1					
2					
3					
4					
5					
6		<p>Bag sexually relentless or aggressive males in a bag separately from their females.</p> <p>Bag territorial or aggressive fish in individual bags.</p>			
7					
8					
9					
10					
11					
12					
13					
14					
15					
16					
17					
18					
19					
20					
21					
22					
23					
24					

MEMBERSHIP APPLICATION .....

**COAST MEMBERSHIP APPLICATION FORM**

MEMBERSHIP RENEWAL .....

Mail to: **Pauline Jackson, COAST Treasurer**

GUEST Registry / AUCTION Sign-In .....

**10926 Ranney Ave, Garden Grove, CA 92843**

(Received by \_\_\_\_\_ Date Rcvd \_\_\_\_\_ Payment \$ \_\_\_\_\_ Member No. \_\_\_\_\_ )

**Yes!** I want to be a member or guest of COAST. Enclosed/attached is my check or money order made payable to **COAST in the amount of \$20** for a one year membership as an individual or family (within the same household please). Senior citizen (aged 62 or over) or junior (aged 20 or under) memberships are \$15 for one year. Members receive our newsletter, Showfish (six to twelve issues a year), and are eligible to participate in our monthly auctions and raffles.

Name \_\_\_\_\_ Email \_\_\_\_\_

Address \_\_\_\_\_ Phone \_\_\_\_\_

City \_\_\_\_\_ State \_\_\_\_\_ Zip Code \_\_\_\_\_

Thank you for your membership and registration. Please tell us how you heard about COAST:

Member  Magazine  Fish Store  Website  Showfish Referred by \_\_\_\_\_

What fish do keep / want to keep? \_\_\_\_\_

What contact information would you like to list in the Membership Roster? (Membership Rosters are COAST property and distributed only within the club to encourage fellowship among members.)

Publish full contact info (default)  Do not publish street address  Do not publish phone  Do not publish email

Unless otherwise specified, the full membership listing of member no., name, phone number, address, city, state and zip code will be listed in our membership directory. Please be sure to notify us of any changes in your contact information, either by email or by using this form.

**Please fill it out completely when you're renewing, too. That's how we keep the membership list correct and up to date.**

**CALIFORNIA'S ORGANIZATION OF AQUATIC SHOW TROPICALS**

COAST is a 501(c)(7) Not-For-Profit Association



<http://www.coastfishclub.com>

c/o C. A. Marelius, Showfish Editor  
16229 Armstead St.  
Granada Hills, CA 91344-3009